



register and win!  
[www.kaercher.com](http://www.kaercher.com)



**KÄRCHER®**

**K 2.20 M**



中文	3
English	9



5.962-875.0 (05/08)

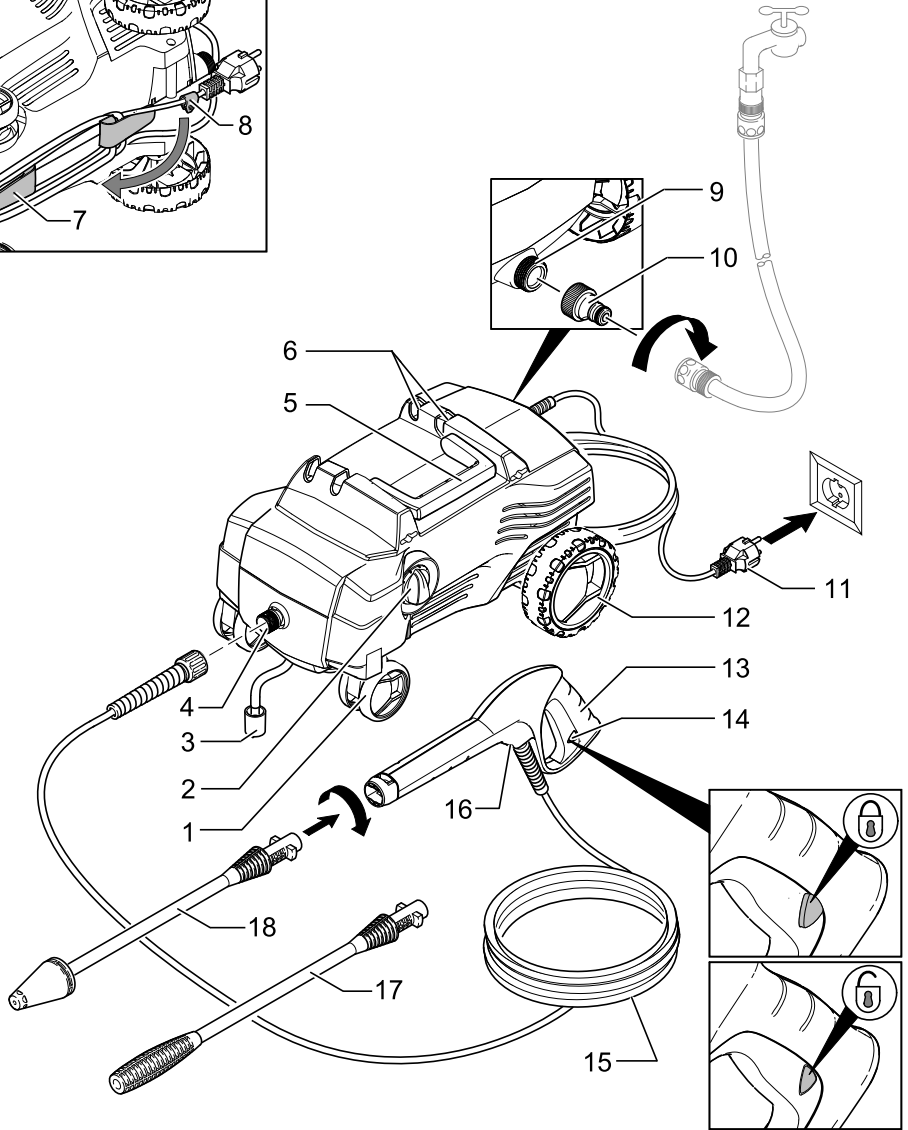
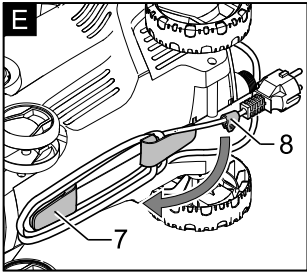
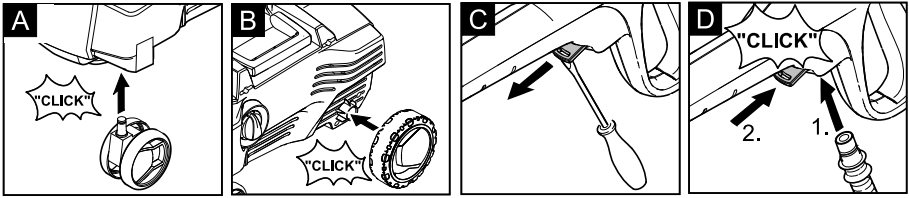

## 目录

设备图 / 供货范围	2
一般事项	3
安全操作说明	4
运行	5
维修与维护	7
故障帮助	7
产品规格 / 参数	8

## 一般事项

### 亲爱的客户：



在您使用本设备之前，请阅读并遵守本说明书的内容。为日后使用或其他所有者使用方便请妥善保管本说明书。

### 危险程度

#### **△ 危险**

即刻引发威胁的危险，致使身体严重伤害或死亡。

#### **△ 警告**

潜藏的危险情况，可能致使身体严重伤害或死亡。

#### **注意**

潜藏的危险情况，可能致使身体轻微伤害或损伤。

### 恰当的使用

本高压式清洗机应当使用在个人家庭用途。

- 利用高压水喷射方式（需要时使用清洁剂），清洗机器、车辆、建筑物外观、阳台、花坛装备等。
- 使用被 KARCHER 认可的附属品、备用零部件和洗涤剂。请参考与洗涤剂所提供的说明部分。

### 环境保护



包装材料可以回收利用。请不要把包装材料与普通垃圾放在一起处理，而应妥善安排回收。



旧的设备中含有宝贵的可再利用的材料，应加以回收利用。请通过适当的收集系统处理您的旧设备。

### 质量保证

我们在各国的经销商已经公布了各国相应的质量保证条款。在质量保证期内，如果您的产品发生了任何故障，我们都将为您提供免费维修，但是这种故障应当是由于机身材料或制造上的缺陷造成的。请您向经销商或者与您距离最近的经过授权的客户服务中心联系，提出保修请求，并提供相应的产品购买证明文件。（地址详见背面。）

### 安全装置

#### **注意**

安全装置就是为了保护使用者，因此不允许随意改造或重组。

#### **设备开关**

设备开关是防止设备偶然的运作。

#### **喷枪操纵杆**

喷枪操纵杆应处于锁紧状态防止设备偶然的开始运作。

## 安全操作说明

### ⚠ 危险

- 请勿用湿手接触插头和插座。
- 请勿使用损伤的电源线和重要部件（例：高压软管、喷射装置、安全装置等）。
- 每次运行前都要确认插头和电源线是否有损坏。若存在损坏的电源线应立即让已授权的客户服务处 / 电气专业人员进行更换。
- 使用前确认高压软管是否损伤。损伤的高压软管应立即更换。
- 禁止在存在爆炸危险的区域内运行本设备。
- 在危险区域（如：加油站）使用设备时应遵守相关的安全规定。
- 不恰当的使用高压软管可能导致危险。喷射时请勿喷向人员、动物、运作时的电机产品或本产品。
- 清洗服装或鞋子时请勿喷向其他人或自身。
- 请勿喷向可能影响健康的危险物质（例：石棉）或物体。
- 车轮或轮胎气门被高压喷射时可能会因损伤而破裂。相关此类事项首次发生的状态为轮胎褪色。损伤的轮胎 / 轮胎气门是致命的。清洗时请保持最小 30 厘米的喷射距离！
- 任何溶解性液体或没稀释的酸性物质和溶剂不允许吸取！这些物质包括汽油、涂料稀释剂或燃料。这些物质的喷雾存在可燃性、爆炸性和毒性特质。请勿使用与丙酮没有稀释的酸性物质及溶剂，因为可能造成本设备的损伤。



### ⚠ 警告

- 电源延长线的插头和结合装置应当防水，勿浸入水中。
- 不适合的电源延长线可能产生危险。仅使用与本设备使用目的相符的带有电源线规格标识的室外用电源延长线。  
1 - 10 m: 1,5 mm<sup>2</sup>; 10 - 30 m: 2,5 mm<sup>2</sup>
- 始终充分松弛电缆卷筒的延长线。
- 高压软管、发电装置部件、电机结合装置部件为设备的稳定性起重要作用。仅

使用由制造公司推荐的高压软管、发电装置部件、电机结合装置部件。

- 必须确保在身体 / 感觉 / 精神能力等方面残障或者缺乏经验和 / 或缺专业知识等人员（包括儿童）不得使用，除非有人对他们的安全进行监督或他们收到如何操作设备的提示。监督儿童，以确保他们不使用设备玩耍。
- 操作人员应按照规定适当地使用本设备。同时要重视地区情况并在设备工作时严密注意周边人员。
- 在其他人员可能达到的距离内请勿使用本设备，除非配着防护服。
- 逆喷射以前为了防水或灰尘应配着适当的防护服和防护镜。

### 注意

- 为了清洗已涂装表面的喷射时，保持最小 30 厘米的喷射距离且不会在涂装表面上造成损伤。
- 设备运行中绝对不允许疏忽大意。
- 需要注意的是，不得碾压、压挤、拖拽或通过诸如此类的行为而损坏电源连接线或延长线缆。避免热源、油或者锋利的刀刃从而保护电源线。
- 在设备运行中产生电流的所有部分应严防喷水。
- 本设备只能根据 IEC 60364 规定，由电工连接到电气接口。
- 本设备仅用于交流电源。使用电压应与本设备类型标识相一致。
- 本着安全的原则，我们公司推荐本设备应通过故障电流安全开关（最大电流为 30 毫安）而使用。
- 产生含有油成分废水的清洗作业（发动机 / 车体底部清洗作业等）应只使用配备油分离器的清洗设备。
- 本设备应使用制造公司供给或推荐的洗涤剂。使用其他的洗涤剂或化学产品可能影响到本设备的安全性。

## 运行

### 设备说明

在打开产品包装的同时，请确认设备附件没有缺失，箱内物品没有损坏。如果您发现运输途中造成损坏，请联系经销商。

#### 图片参见第 2 页

- 1 可旋转脚轮
- 2 产品开关“0/OFF” / “I/ON”
- 3 洗涤剂吸取软管（过滤器）
- 4 高压接口
- 5 手柄
- 6 喷头指示
- 7 电源连接导线的维护
- 8 电源连接导线的电缆接线夹
- 9 带安装有滤网的水接口
- 10 水接口单元
- 11 连接线 / 插头
- 12 移动轮胎
- 13 手持喷枪
- 14 喷枪操纵杆
- 15 高压软管
- 16 高压软管夹
- 17 高压喷嘴喷头
- 18 除却杂质喷头

#### 特殊附属配件

特殊附属配件的使用可延长设备的使用寿命。详细事项请联系 KARCHER 产品的销售处。

### 设备运作前

运作前将松弛的部件结合到设备。

#### 图片参见第 2 页

##### 图 A

→ 插入可旋转脚轮并锁紧。

##### 图 B

→ 插入运输轮并锁紧。

##### 图 C

→ 分离喷枪高压软管夹（例：利用小型螺丝刀）。

##### 图 D

→ 插入喷枪高压软管。

→ 卡入管夹直至稳固。拉高压软管以检查是否安全连接。

## 水供给

根据有效的规定，不带系统分离装置的设备在饮水系统上不允许运作。应使用与 KARCHER 相符的系统分离装置或依据 EN12729 类型 BA 的系统分离装置。



**注意：**水中杂质可能损伤高压泵和部件。为防止此类状况，我们公司推荐使用 KARCHER 水过滤器（特殊部件、货号：4.730-059）。

#### 来自水管的水供给

重视水供给的注意事项。

连接参数详见类型规格标识 / 产品参数。

- 使用具备标准结合装置的强化型水软管（不配备）。（直径最小 1/2 英寸或最小 13 毫米；长度最短为 7.5 米）
- 将结合装置（配备）连接至供水位置。
- 将供水软管固定至结合装置后连接供水系统。

### 调试设备

#### 注意

无水运作时高压泵可能会损伤，水龙头关闭时绝对不使用高压清洗机。

- 将高压软管连接至设备高压软管部位。
- 将喷头置入喷枪后成 90° 旋转固定。
- 完全打开水龙头。
- 电源连接导线完全展开。
- 插上电源插头。
- 将设备设定为“I/ON”。

## 设备运作

### △ 危险

自高压喷头喷水会带给喷枪逆冲击。为安全起见，请牢固喷枪和喷头。

- 松开喷杆。
- 拉喷杆启动设备。

**注意：**再拉喷杆停止设备。高压残留于系统内。

### 高压喷嘴喷头

适用于正常的清洗作业中。  
不适合于用洗涤剂的清洗作业。

### 除却杂质喷头

适用于含难处理杂质的清洗作业。  
不适合于用洗涤剂的清洗作业。

### 移动设备

- 运行时设备应拧紧到高压软管上。

### 注意

- 当电源连接导线展开后，才可以移动设备。
- 只有当设备位于视野内，方可移动设备。
- 该设备不是用来运输物品。

**提示：**为扩大活动范围，把电源连接导线充分加长。

## 使用洗涤剂的清洗作业

每次执行清洁任务时请只使用 K 鋇 cher 公司的清洁剂和护理液，因为它们是专门为您的仪器开发研制的。如果使用其它清洁剂和护理液，则会加快磨损，我们也将因此取消质保。相关信息请咨询专门经销商或直接向 KARCHER 公司征求信息。

- 自保管箱中拉出所需长度的洗涤剂吸取软管。
- 在洗涤溶液筒中悬挂吸取软管。
- 自喷枪分离喷头。仅用喷枪运作。

**注意：**由此，使用时洗涤剂溶解物混入喷出的水柱之中。

### 推荐的清洗方法

- 在干燥的表面上少量喷射洗涤剂，（在不干透的情况下）发生反应。
- 利用高压喷射方式刷洗被溶解的杂质。

## 设备运作中断

- 松开喷杆。
- 分离喷枪。
- 然后，长时间（5 分钟以上）运作中断时，将设备开关设定为“0/OFF”。

## 设备结束操作

### 注意

当系统中无可用压力，就要把高压软管从手持喷枪或设备上拆下来。

- 使用洗涤剂清洗作业后，在干净水的桶中悬挂吸取软管，约 1 分钟刷洗拔除喷头后运作状态下的装置。
- 松开喷杆。
- 将设备设定为关闭“0/OFF”。
- 关闭水龙头。
- 自供水处分离设备。
- 按压喷杆以除去在设备系统中残留的压力。
- 分离喷枪。
- 从设备高压连接部位分离高压软管。
- 维护喷射管时锁紧喷射管。
- 取下插头。

### 图 10

- 出于维护考虑，把电源连接导线卷起来并用电缆接线夹固定电源插头。

## 维修与维护

### ⚠ 危险

在对设备进行维修与维护之前，必须关闭设备并拔下电源插头。

### 维护

免费提供设备维修

### 保管

冬季等长时间保管前：

- 完全排空设备内的水：打开不带高压软管和供水连接装置的设备（最大1分钟），等待直至无水从高压连接部位出来时。关闭设备。
- 从洗涤剂吸取软管分离过滤器后用水清洗。
- 用扁嘴钳分离微细过滤器后用水清洗。

### 运输

- 抓握器提起设备，不开动。

### 防霜

### 注意

设备和附属品的防霜。

在水没有完全排空的情况下，设备和附属品或许会因含霜而破损。防止损伤：

- 完全配备附属品的设备应在防霜的室内保管。

### 备件

请仅使用 KARCHER 的原始备件。在本说明书后附有一份备件总览表。

## 故障帮助

参考下记的帮助事项可处理很多故障。

存在疑问时请联系本公司认可的客户服务部。

### ⚠ 危险

在对设备进行维修与维护之前，必须关闭设备并拔下电源插头。

维修作业和相关电机附件的作业仅应在本公司认可的客户维修部。

### 设备不运作

- 检查电源电压必须跟型号标识上给出的电压一致。
- 检查电源线是否损伤。

### 设备压力不足

- 设备通风：在没有连接高压软管的状态下，使之运作直至软管连接部位不再出现水泡沫。关闭设备再连接高压软管。
- 检查供水连接系统。
- 用扁嘴钳分离微细过滤器后用水清洗。

### 强大的压力变化

- 高压清洗：用针除去喷头孔处的杂物，在前面用水清洗。
- 检查供水连接系统。

### 设备漏水

- 在技术方面可能存在高压泵少许漏水的情况。漏水量较大时请联系本公司认可的客户服务部。

### 洗涤剂不被吸取

- 自喷枪分离喷头。仅用喷枪运作。
- 清洗洗涤剂吸取软管的过滤网。
- 检查洗涤剂吸取软管是否扭曲。

## 产品规格 / 参数

### 通电

电压	220 V 1~50 Hz
----	------------------

输入电力	1, 4 kW
------	---------

保险丝（缓熔型）	10 A
----------	------

保护等级	II
------	----

保护程度	IP X5
------	-------

### 水接口

流入温度（最大）	40 ° C
----------	--------

流入量（最小）	8 l/分
---------	-------

流入压力	0, 2-1, 2 MPa
------	---------------

### 性能参数

作动压力	8 MPa
------	-------

最大允许压力	11 MPa
--------	--------

注水比例	5, 5 l/分
------	----------

注入洗涤剂比例	0, 3 l/分
---------	----------

喷枪逆喷射能力	10 N
---------	------

手的震荡值 (ISO 5349)	0, 8 m/s <sup>2</sup>
---------------------	-----------------------

音压水准 L <sub>pA</sub> (EN60704-1)	76 A 级分贝
-------------------------------------	----------

音力水准 L <sub>WA</sub> (2000/14/EG)	90 A 级分贝
--------------------------------------	----------

### 尺寸

长度	448 毫米
----	--------

宽度	283 毫米
----	--------

高度	252 毫米
----	--------

重量	4, 7 千克
----	---------

**技术参数可能会有变化!**



## Contents

Illustration of appliance / scope of delivery	2
General information	9
Safety instructions	10
Operation	11
Maintenance and care	13
Troubleshooting	14
Technical specifications	14

## General information

### Dear Customer,



Please read and comply with these instructions prior to the initial operation of your appliance. Retain these operating instructions for future reference or for subsequent possessors.

### Hazard levels

#### **Danger**

*Immediate danger that can cause severe injury or even death.*

#### **Warning**

*Possible hazardous situation that could lead to severe injury or even death.*

#### **Caution**

*Possible hazardous situation that could lead to mild injury to persons or damage to property.*

### Proper Use

This high-pressure cleaner is designed for domestic use only:

- to clean machines, vehicles, buildings, tools, facades, terraces, garden equipment etc. using a high-pressure water jet (and detergents if required).
- with accessories, replacement parts and detergents approved by KÄRCHER. Observe the instructions provided with these detergents.

### Environmental protection



The packaging material can be recycled. Please do not place the packaging into the ordinary refuse for disposal, but arrange for the proper recycling.



Old appliances contain valuable materials that can be recycled. Please arrange for the proper recycling of old appliances.

Please dispose your old appliances using appropriate collection systems

### Warranty

The warranty terms published by our competent sales company are applicable in each country. We will repair potential failures of your appliance within the warranty period free of charge, provided that such failure is caused by faulty material or defects in fabrication. In the event of a warranty claim please contact your dealer or the nearest authorized Customer Service center. Please submit the proof of purchase. (See address on the reverse)

### Safety Devices

#### **Caution**

*Safety devices protect the user and must not be modified or bypassed.*

#### **Power switch**

The appliance switch prevents unintentional operation of the appliance.

#### **Lock trigger gun**

This lock locks the lever of the trigger gun and prevents the inadvertent start of the appliance.

## Safety instructions

### **⚠ Danger**

- Never touch the mains plug and the socket with wet hands.
- The appliance must not be used if the power cord or important parts of the appliance, e.g. high-pressure hoses, trigger gun or safety devices are damaged.
- Check the power cord with mains plug for damage before every use. If the power cord is damaged, please arrange immediately for the exchange by an authorized customer service or a skilled electrician.
- Check the high-pressure hose for damage before every use. Please arrange for the immediate exchange of a damaged high-pressure hose.
- The appliance may not be used in areas where a risk of explosion is present.
- If the appliance is used in hazardous areas (e.g. filling stations) the corresponding safety provisions must be observed.
- High-pressure jets can be dangerous if improperly used. The jet must not be directed at persons, animals, live electrical equipment or at the appliance itself.
- The high-pressure jet must not be directed at other persons or directed by the user at him/herself to clean clothing or footwear.
- Never use the appliance to clean objects containing hazardous substances (e.g. asbestos).
- Vehicle tyres or tyre valves are susceptible to damage from the high-pressure jet and may burst. The first indication of this is a discolouration of the tyre. Damaged vehicle tyres/tyre valves are highly dangerous. Ensure that a distance of at least 30 cm is observed when cleaning with the jet!
- Never draw in fluids containing solvents or undiluted acids and solvents! This includes petrol, paint thinner and heating oil. The spray mist thus generated is highly inflammable, explosive and poisonous. Do not use acetone, undiluted acids and solvents as they are aggressive towards the materials from which the appliance is made.



### **⚠ Warning**

- The mains plug and the coupling of an extension cable must be watertight and must never lay in the water.
- Unsuitable extension cables can be hazardous. Only use extension cables outdoors which have been approved for this purpose and labelled with a sufficient cable cross-section:  
1 - 10 m: 1.5 mm<sup>2</sup>; 10 - 30 m: 2.5 mm<sup>2</sup>
- Always fully unroll electrical cables from the cable drum.
- High-pressure hoses, fixtures and couplings are important for the safety of the appliance. Only use high-pressure hoses, fixtures and couplings recommended by the manufacturer.
- This device is not intended for use by persons (including children) with reduced physical, sensory or mental abilities or lacking experience and/or knowledge, unless they are supervised by a person responsible for their safety or are instructed by these persons on the use of the device. Children should be supervised, to ensure that they do not play with the device.
- The operator must use the appliance correctly. When working with the appliance, he must consider the local conditions and pay due care and attention to other persons, in particular children, who are nearby.
- Do not use the appliance when there are other persons around unless they are also wearing safety equipment.
- Wear protective clothing and safety goggles to protect against splash back containing water or dirt.

### **Caution**

- Observe a distance of at least 30 cm when using the jet to clean painted surfaces to avoid damaging paintwork.
- Never leave the appliance unattended when it is in operation.
- Make sure that the power cable or extension cables are not damaged by running over, pinching, dragging or similar. Protect the power cable from heat, oil, and sharp edges.
- All current-conducting parts in the working area must be protected against jet water.
- The appliance may only be connected to an electrical supply which has been installed in accordance with IEC 60364.

- *The appliance may only be connected to alternating current. The voltage must correspond with the type plate on the appliance.*
- *For safety reasons, we recommend that you operate the appliance only via a earth-leakage circuit breaker (max. 30 mA).*
- *Cleaning operations which produce oily waste water, e.g. engine washes, underbody washes, may only be carried out using washing stations equipped with an oil separator.*
- *This appliance was designed to be used with detergents which are supplied or recommended by the manufacturer. The use of other detergents or chemicals may compromise the safety of the appliance.*

## Operation

### Description of the Appliance

When unpacking the product, make sure that no accessories are missing and that none of the package contents have been damaged. If you detect any transport damages please contact your dealer.

#### Illustrations on Page 2

- 1 Swivel casters
- 2 Appliance switch "0/OFF"/ „I/ON"
- 3 Detergent suction hose (with filter)
- 4 High pressure connection
- 5 Carrying handle
- 6 Storage for spray lance
- 7 Storage for mains connection cable
- 8 Cable clamp for mains connection cable
- 9 Water connection with integrated sieve
- 10 Coupling element for water connection
- 11 Mains cable with mains plug
- 12 Bearing wheel
- 13 Trigger gun
- 14 Lock trigger gun
- 15 High pressure hose
- 16 Clamp for high pressure hose
- 17 Spray lance with high pressure nozzle
- 18 Spray lance with dirt blaster

#### Special accessories

Special accessories expand the possibilities of using your appliance. Please contact your KÄRCHER dealer for further information.

### Before Startup

Mount loose parts delivered with appliance prior to start-up.

#### Illustrations on Page 2

Illustration **A**

→ Insert the steering rollers and lock them.

Illustration **B**

→ Insert the transport wheels and lock them.

Illustration **C**

→ Pull out the clamp for the high-pressure hose from the trigger gun (e.g. a small screwdriver).

Illustration **D**

→ Connect high pressure hose to trigger gun.

→ Push the clamp in until it locks. Check the secure connection by pulling on the high-pressure hose.

## Water supply

According to the applicable regulations, the appliance must never be used on the drinking water supply without a system separator. Use a suitable system separator manufactured by KÄRCHER; or, as an alternative, a system separator as per EN 12729 Type BA.



**Note:** Impurities in the water can damage the high-pressure pump and accessories. For protection, the use of the KÄRCHER water filter (optional accessory, order no. 4.730-059) is recommended.

### Water supply from mains

Observe regulations of water supplier.

For connection values, see type plate/technical data.

- ➔ Use a fibre-reinforced water hose (not included) with a standard coupling. (Minimum diameter 1/2 inch (13 mm), minimum length 7.5 m).
- ➔ Screw the coupling unit (supplied) to the water connection on the appliance.
- ➔ Push the water supply hose onto the coupling unit, then connect it to the water supply.

## Start up

### Caution

*Never operate the high-pressure cleaner when the tap is turned off as dry running will damage the high-pressure pump.*

- ➔ Connect the high pressure hose to the high pressure connection of the appliance.
- ➔ Push the spray lance into the trigger gun and fasten it by turning it through 90°.
- ➔ Completely open the water tap.
- ➔ Fully unroll power cable.
- ➔ Insert the mains plug into the socket.
- ➔ Turn on the appliance "I/ON".

## Operation

### ⚠ Danger

*The trigger gun is subjected to a recoil force when the water jet is discharged. Make sure that you have a firm footing and are also holding the trigger gun and spray lance firmly.*

- ➔ Unlock the lever on the trigger gun.
- ➔ Pull on the lever of the trigger gun; the device will switch on.

**Note:** Release the lever of the trigger gun; the device will switch off again. High pressure remains in the system.

### Spray lance with high pressure nozzle

For normal cleaning tasks.

Not suitable for use with detergents.

### Spray lance with dirt blaster

For particularly dirty items or areas.

Not suitable for use with detergents.

### Move the appliance

- ➔ The appliance can be pulled by the high-pressure hose during operation.

### Caution

- *Only pull the appliance if the mains connecting cable is unwound.*
- *Only pull the appliance while you can see it.*
- *Do not use the appliance to transport objects.*

**Tip:** In order to increase the action radius, extend the mains cable sufficiently.

## Working with detergent

Please use exclusively KÄRCHER detergents and care products to carry out the respective cleaning task, as these were specifically developed for your appliance. The use of other detergents and care products may lead to premature wear and can invalidate your warranty claims. Please obtain information at your local dealer or request information directly from KÄRCHER.

- ➔ Pull detergent suction hose as far as is required out of the housing.
- ➔ Suspend end of detergent suction hose in a container filled with detergent.
- ➔ Detach spray lance from the trigger gun. Work only with the trigger gun.

**Note:** This will mix the detergent with the water stream.

### Recommended cleaning method

- ➔ Spray the detergent sparingly on the dry surface and allow it to react, but not to dry.
- ➔ Spray off loosened dirt with the high-pressure jet.

## Interrupting operation

- Release the lever on the trigger gun.
- Lock the lever on the trigger gun.
- During longer breaks (more than 5 minutes), also turn the appliance off using the "0/OFF" switch.

## Finish operation

### Caution

*Only separate the high-pressure hose from the trigger gun or the appliance while there is no pressure in the system.*

- After working with detergent, suspend detergent suction hose in a container filled with clear water, switch the appliance on for around 1 minute once the spray lance has been removed and rinse until water runs clear.
  - Release the lever on the trigger gun.
  - Turn off the appliance "0/OFF".
  - Turn off tap.
  - Detach the appliance from the water supply.
  - Press the lever on the trigger gun to release any remaining pressure in the system.
  - Lock the lever on the trigger gun.
  - Separate the high pressure hose from the high pressure connection point of the appliance.
  - Engage the spray lance in its compartment.
  - Pull out the mains plug.
- Illustration 
- Wrap the mains power cable around the hose drum and attach the mains plug with a cable clamp.

## Maintenance and care

### **Danger**

*Turn off the appliance and remove the mains plug prior to any care and maintenance work.*

## Maintenance

The appliance is maintenance-free.

## Storage

Prior to longer periods of storage, e.g. in the winter:

- Completely drain all water from the appliance: Switch the appliance on with detached high-pressure hose and detached water supply (max. 1 minute) and wait, until no more water exits at the high-pressure connection. Turn off the appliance.
- Remove filter from suction hose for detergent and clean under running water.
- Pull out the sieve in the water connection using flat-nose pliers and clean under running water.

## Transport

- Carry appliance at carrying handle, do not drive.

## Frost protection

### Caution

*Protect the appliance and its accessories against frost.*

The appliance and its accessories can get destroyed through frost if there are any water residues in them. To avoid damage to them:

- Store the appliance and the entire accessories in a frost-safe room.

## Spare parts

Use only original KÄRCHER spare parts. You will find a list of spare parts at the end of these operating instructions.

## Troubleshooting

You can rectify minor faults yourself with the help of the following overview.

If in doubt, please consult the authorized customer service.

### **Danger**

*Turn off the appliance and remove the mains plug prior to any care and maintenance work. Repair works may only be performed by the authorized customer service.*

#### **Appliance is not running**

- ➔ Check whether the voltage indicated on the type plate corresponds to the voltage of the mains supply.
- ➔ Check the mains connection cable for damages.

#### **Pressure does not build up in the appliance**

- ➔ Appliance ventilation: Switch the appliance on with the high-pressure hose detached and operate until the water flows through the high-pressure connection without bubbles. Switch off appliance and reconnect high-pressure hose.
- ➔ Check the water supply.
- ➔ Pull out the sieve in the water connection using flat-nose pliers and clean under running water.

#### **Strong pressure fluctuations**

- ➔ Clean high-pressure nozzle: Remove dirt and debris from the nozzle bore, using a needle and rinse through with water from the front.
- ➔ Check water flow quantity.

#### **Appliance is leaking**

- ➔ Slight leakage from the appliance pump is normal. If the leakage increases contact the authorized customer service.

#### **No detergent infeed**

- ➔ Detach spray lance from the trigger gun. Work only with the trigger gun.
- ➔ Clean the detergent suction hose filter.
- ➔ Check the detergent suction hose for kinks.

## Technical specifications

### **Power connection**

Voltage	220 V 1~50 Hz
---------	------------------

Connected load	1,4 kW
----------------	--------

Mains fuse (slow-blow)	10 A
------------------------	------

Protective class	II
------------------	----

Protection class	IP X5
------------------	-------

### **Water connection**

Max. feed temperature	40 °C
-----------------------	-------

Min. feed volume	8 l/min
------------------	---------

Feed pressure	0,2-1,2 MPa
---------------	-------------

### **Performance data**

Working pressure	8 MPa
------------------	-------

Max. permissible pressure	11 MPa
---------------------------	--------

Water flow rate	5,5 l/min
-----------------	-----------

Detergent flow rate	0,3 l/min
---------------------	-----------

Recoil force of trigger gun	10 N
-----------------------------	------

Hand-arm vibration (ISO 5349)	0,8 m/s <sup>2</sup>
----------------------------------	----------------------

Sound pressure level	76 dB(A)
----------------------	----------

L <sub>pA</sub> (EN60704-1)	
-----------------------------	--

Sound power level	90 dB(A)
-------------------	----------

L <sub>WA</sub> (2000/14/EG)	
------------------------------	--

### **Dimensions**

Length	448 mm
--------	--------

Width	283 mm
-------	--------

Height	252 mm
--------	--------

Weight	4,7 kg
--------	--------

### **Subject to technical modifications!**

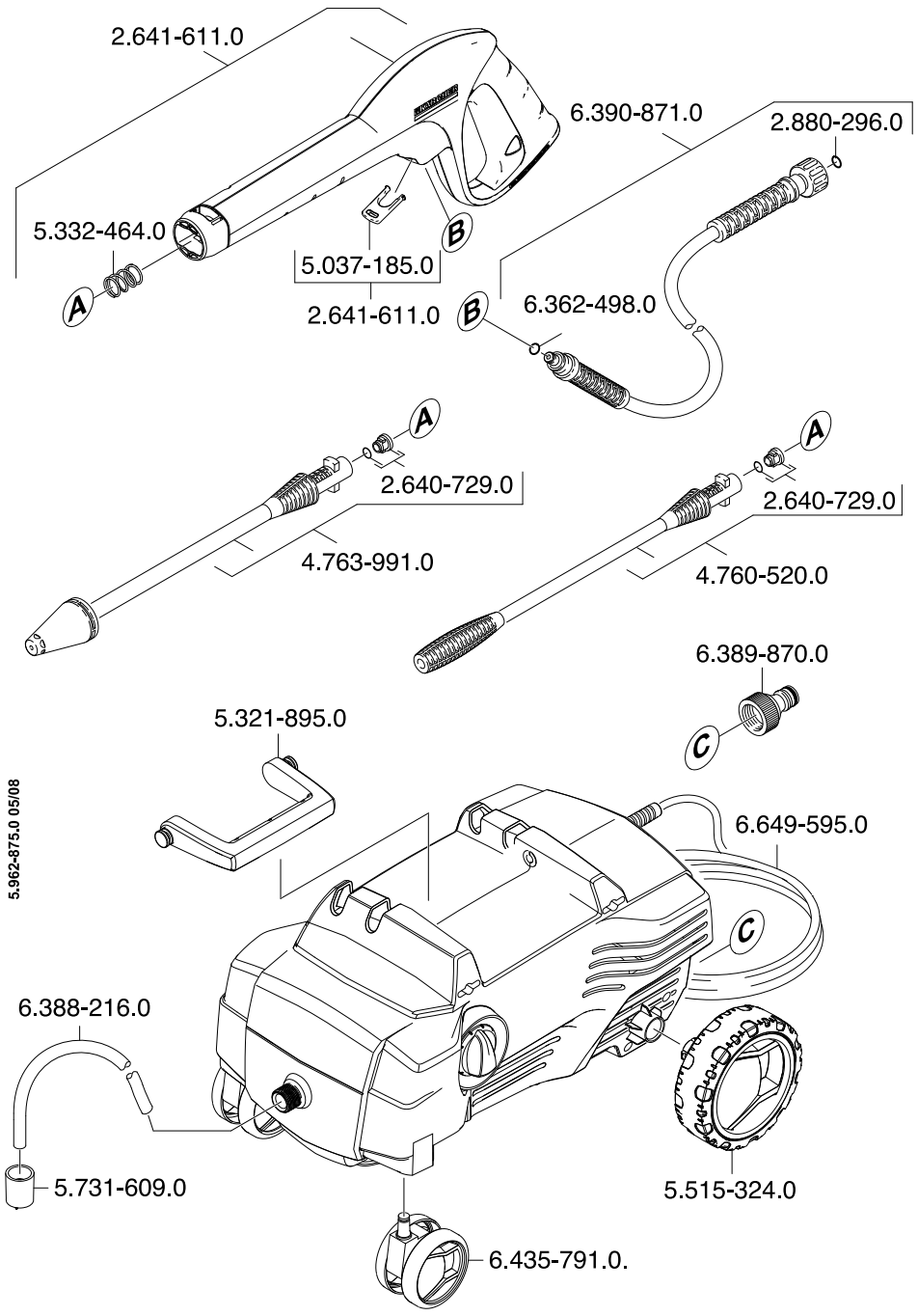

5.962-875.0 05/08

**A**

Alfred Kärcher Ges.m.b.H.  
Lichtblaustraße 7  
1220 Wien  
☎ (01) 25 06 00

**AUS**

Kärcher Pty. Ltd.  
40 Koornang Road  
Scoresby VIC 3179  
☎ (03) 9765 - 2300

**B / LUX**

Kärcher N.V.  
Industrieweg 12  
2320 Hoogstraten  
☎ 0900 - 33 444 33

**BR**

Kärcher Indústria e Comércio Ltda.  
Av. Prof. Benedicto Montenegro 419  
CEP 13.140-000 - Paulínia - SP  
☎ 0800 17 61 11

**CH**

Kärcher AG  
Industriestraße 16  
8108 Dällikon  
☎ 0844 850 863

**CZ**

Kärcher spol. s.r.o.  
Za Mototechnou 1114/4  
155 00 Praha 5 - Stodůlky  
☎ (02) 3552-1665

**D**

Alfred Kärcher GmbH & Co. KG  
Service-Center Gissigheim  
Im Gewerbegebiet 2  
97953 Königheim-Gissigheim  
☎ (07195) 903 20 65

**DK**

Kärcher Rengøringsystemer A/S  
Gejlhavegård 5  
6000 Kolding  
☎ 70 20 66 67

**E**

Kärcher S.A.  
Pol. Industrial Font del Radium  
Calle Doctor Trueta 6-7  
08400 Granollers (Barcelona)  
☎ 902 17 00 68

**F**

Kärcher S.A.S.  
5 Avenue des Coquelicots  
Z.A. des Petits Carreaux  
94865 Bonneuil-sur-Marne  
☎ (01) 43 99 67 70

**FIN**

Kärcher OY  
Yrittäjätie 17  
01800 Klaukkala  
☎ 0207 413 600

**GR**

Kärcher Cleaning Systems A.E.  
31-33, Nikitara & Konstantinoupoleos str.  
13671 Acharnes  
☎ 210 - 23 16 153

**GB**

Kärcher(UK) Limited  
Kärcher House  
Beaumont Road  
Banbury  
Oxon, OX16 1TB  
☎ 01295 752200

**H**

Kärcher Hungária Kft  
Tormásrét ut. 2.  
2051 Biatorbágy  
☎ (023) 530-640

**HK**

Kärcher Limited  
Unit 10, 17/F.  
APEC Plaza  
49 Hoi Yuen Road  
Kwun Tong, Kowloon  
☎ (02) 357-5863

**I**

Kärcher S.p.A.  
Via A. Vespucci 19  
21013 Gallarate (VA)  
☎ 848 - 99 88 77

**IRL**

Kärcher Limited (Ireland)  
12 Willow Business Park  
Nangor Road  
Clondalkin  
Dublin 12  
☎ (01) 409 77 77

**KOR**

Kärcher Co. Ltd. (South Korea)  
Youngjae B/D, 50-1, 51-1  
Sansoo-dong, Mapo-ku  
Seoul 121-060  
☎ 032-465-8000

**MAL**

Kärcher Cleaning Systems Sdn. Bhd.  
No. 8, Jalan Serindit 2  
Bandar Puchong Jaya  
47100 Puchong, Selangor  
☎ (03) 5882 1148

**N**

Kärcher AS  
Stanseveien 31  
0976 Oslo  
☎ 24 17 77 00

**NL**

Kärcher BV  
Postbus 474  
4870 AL Etten-Leur  
☎ 0900-33 444 33

**NZ**

Kärcher Limited  
12 Ron Driver Place  
East Tamaki, Auckland  
☎ (09) 274-4603

**PRC**

Kärcher Cleaning Systems Co., Ltd.  
Part B, Building 30,  
No. 390 Ai Du Road  
Shanghai Waigaoqiao 200131  
☎ (021) 5046-3579

**P**

Neoparts Com. e Ind. Automóvel, Lda.  
Largo Vitorino Damásio. 10  
1200 Lisboa  
☎ (21) 395 0040

**PL**

Kärcher Sp. z o.o.  
Ul. Stawowa 140  
31-346 Kraków  
☎ (012) 6397-222

**RUS**

Kärcher Ltd.  
Vienna House  
Strastnoi Blv. 16  
107031 Moscow  
☎ 095-933 87 48

**S**

Kärcher AB  
Tagenevägen 31  
42502 Hisings-Kärra  
☎ (031) 577-300

**SGP**

Kärcher Asia Pacific Pte. Ltd.  
5 Toh Guan Road East  
#01-00 Freight Links Express Distripark  
Singapore 608831  
☎ 6897-1811

**TR**

Kärcher Servis Ticaret A.S.  
9 Eylül Mahallesi  
307 Sokak No. 6  
Gaziemir / Izmir  
☎ (0232) 252-0708

**TWN**

Kärcher Limited  
5F/6. No.7  
Wu-Chuan 1st Rd  
Wu-Ku Industrial Zone  
Taipei County  
☎ (02) 2299-9626

**UA**

Kärcher Ukraine  
Kilzeva doroga, 9  
03191, Kyiv  
☎ (044) 5947575

**UAE**

Kärcher FZE  
Jebel Ali Free Zone  
RA 8, XB 1, Jebel Ali, Dubai  
☎ (04) 8836-776

**ZA**

Kärcher (Pty.) Limited  
144 Kuschke Street  
Meadowdale  
Edenvale 1614  
☎ (011) 574-5360

02/2008



www.kaercher.com