

中文 3
English 7

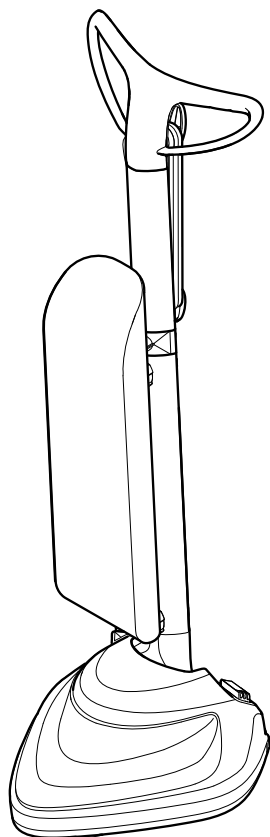

Register and win!
www.karcher.com

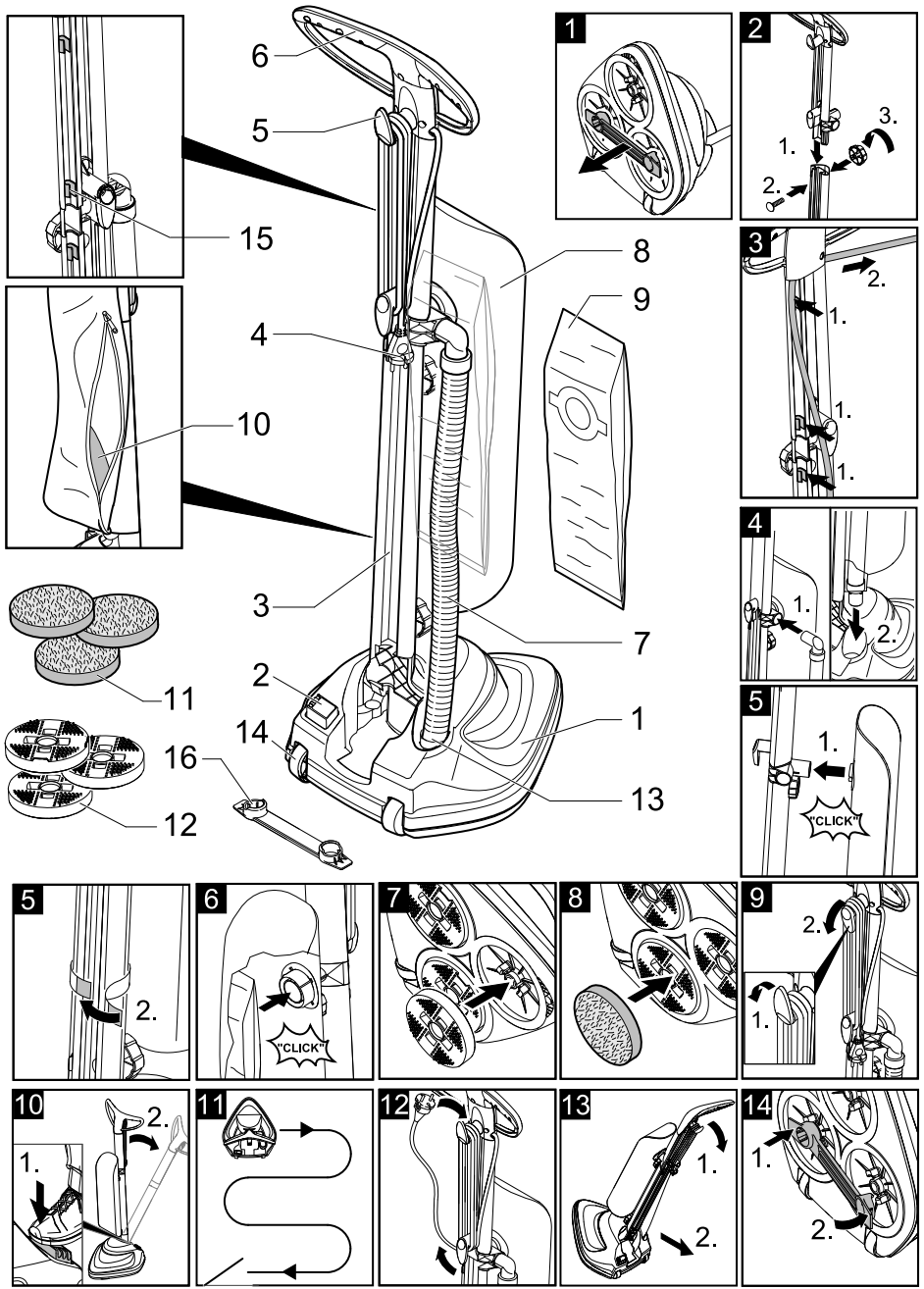



目录

安全说明	3
调试	4
操作说明	5
结束设备操作	5
保养与维护	6
一般提示:	6
排除故障帮助	6
产品规格 / 参数	6

亲爱的客户:



在您使用本设备之前, 请阅读并遵守本说明书的内容。为日后使用或其他所有者使用方便请妥善保管本说明书。

合乎规定的使用

- 该吸尘器开发用于私家用途, 并非设计满足工商业使用要求。
- 本设备允许用于打磨木地板、复合地板、石材地板、油毡和聚氯乙烯塑料地板。
- 本设备只适合于抽吸打磨粉末。
- 该设备不是吸尘器! 不可用于干物吸!
- 不使用含溶剂的护理剂。
- 本设备不得应用在地毯等类似地垫上。
- 不要让本设备承受额外的重量。
- 不得在室外或潮湿条件下使用或停放设备。
- 本设备只与原配过滤袋以及原配备件、附件或特殊附件一起使用。
- 设备运行时始终移动设备。不要长久停留在一个地方, 否则可对地板造成损害。
- 请始终注意地板制造商和护理剂制造商的提示!

对于由于执行未规定的使用或错误的操作造成的可能的损失, 制造商将不承担任何责任。

环境保护



包装材料可以回收利用。请不要把包装材料与普通垃圾放在一起处理, 而应妥善安排回收。



旧的设备中含有宝贵的可再利用的材料, 应加以回收利用。请通过适当的收集系统处理您的旧设备。

内部材料提示 (REACH)

最新的内部材料信息请您在如下链接中查找:

www.kaercher.com/REACH

安全说明

接电

- 只根据铭牌说明连接和使用本设备。
- 决不能用湿的手触摸电源插头。
- 切断机器电源时, 请拔下插头, 而不要直接拉扯电源线。
- 不要碾压、挤压、拖曳电源线或延长线缆或采取类似行为而将其损伤或损坏。防止电源线受热、油和尖锐棱角的损坏。
- 保护设备免受外部天气、潮湿和热源的影响。

应用

- 工作间歇或无人看管设备时, 关闭总开关 / 设备开关或拔下电源插头。
- 必须确保在身体 / 感觉 / 精神能力等方面残障或者缺乏经验和 / 或缺专业知识等人员 (包括儿童) 不得使用, 除非有人对他们的安全进行监督或他们收到如何操作设备的提示。监督儿童, 以确保他们不使用设备玩耍。
- 操作人员按照规定使用本设备。同时要重视地方现行的规定并在设备工作时照顾好第三者, 特别是儿童。
- 操作人员必须注意不要让那些有可能被转动的打磨片卷入和甩出的物品遗留在工作区域内。

运输

- 设备运输时发动机是停止的并注意务必绑牢设备。

保养

- 在设备上所有工作前拔下电源插头。
- 为了避免产生危害, 只允许经过授权的客户服务中心对设备进行维修和更换备件。

调试

设备说明

- 1 打磨头
- 2 用于锁定手杆的脚踏开关
- 3 把手
- 4 带插头的电源电缆线
- 5 维护，电源线
- 6 手柄
- 7 抽吸软管
- 8 纺织品袋子
- 9 过滤器袋
- 10 打磨垫存放盒
- 11 打磨垫
- 12 打磨垫支架
- 13 抽吸软管接头
- 14 运输滚轮
- 15 电源线固定夹（4个）
- 16 运输保险装置

去除运输保险装置

图 1

- 初次接触设备和在使用设备前拔下运输保险装置。

组装并安置手杆

图 2

- 将手杆的两个部分对插在一起并使用所附螺栓和螺帽进行保险固定。
- 将整个手杆插到打磨头中并使用螺栓进行固定。

提示：在此注意电源线的位置。

图 3

- 将电源线压到固定夹中并拉紧。

连接吸尘软管

图 4

- 将吸尘软管的直端头插到打磨头中，弯端头则插到手杆上的接头中。

安置纺织品袋子

图 5

- 首先将纺织品袋子的上半部分压到卡座中，直至卡住。
- 接着使用粘扣带将下半部分固定在手杆上。

安放过滤袋

图 6

- 打开纺织品袋子的拉链。
- 放进过滤袋并将带开口的纸盒推到接管上，直至卡住。再次检查过滤袋是否正确定位。
- 拉动拉链重新将纺织品袋子合上。

安放打磨垫支架

图 7

- 设备放在地上时应使打磨头垂直于地面。
- 将打磨垫支架简单压入卡座中。注意打磨垫支架的卡鼻必须正确卡到卡座中。
- 取出时只须简单拔下打磨垫支架。

放上打磨垫

图 8

- 将打磨垫放到打磨垫支架上，注意调整对中。
- 取出时只须简单拔下打磨垫。

塞进打磨垫

- 打磨垫可以保存在纺织品袋子下半部分一个单独的格层中。

操作说明

提示:

始终使用安放好的过滤袋进行工作。

△ 注意

在插入电源插头前必须确保手杆处于垂直位置。在此位置下关闭设备。

图 9

→ 转动上方的电源线钩子并取下电源线。将电源插头插到插座中。

图 10

→ 移动设备，使用脚踏开关将手杆锁定并向身体方向拉动手柄。

→ 为了停住设备，沿垂直方向拉回手杆，直到它被卡住为止。

全护理

建议每年进行 2-3 次全护理。

地板去污

→ 对地垫 / 地板进行清扫、吸尘或者在需要时打成雾气潮湿后擦干净。

涂抹护理剂

→ 用拖把将护理剂均匀涂到地板上。让地板完全干燥

提示: 注意地板制造商和护理剂制造商的应用提示!

不使用含溶剂的护理剂。

打磨

图 11

→ 如图所示，多次在地面上碾磨，直到达到所希望的光洁度。

设备运行时始终移动设备。不要长久停留在一个地方，否则可对地板造成损害。

提示: 是否可以在地面上行走或移动家具，请遵照制造商的说明。我们建议至少等待 12 个小时。在此时间内小心且不要穿上街时穿的鞋子在打磨好的地面上行走。不要移动家具，不要将水洒到地板上。

日常护理

建议每月进行一次日常护理，以达到均衡的光洁度。

→ 视具体的护理剂制造商而定，护理剂可直接加到擦洗水中。注意地板制造商和护理剂制造商的提示!

→ 接着打磨地面。

临时护理

→ 视需要和地板的脏污情况（脚印、条痕……），不需要预先涂上新护理剂即可再次打磨护理层。

结束设备操作

→ 将手杆放回到垂直位置。关闭设备。

图 12

→ 拔下电源插头并将电源线卷绕到安置在手杆上的钩子上。预先向上转动上方的电源线钩子。

设备运输

如果想要将设备移动到存放地点或者另外一个房间内，则请注意将设备放在运输滚轮上进行移动。

图 13

→ 同时将手柄向后倾斜并拉动设备。

设备储存

如果较长时间不使用设备，则建议将运输保险装置固定好。

图 14

→ 设备放在地上时应使打磨头垂直于地面。

→ 拔下设备的打磨垫支架并放在存放盒中。

→ 将运输保险装置的一侧压低并卡到打磨垫支架的卡座中。将运输保险装置的另外一侧紧紧压入并卡到第二个打磨垫支架的卡座中。

→ 将设备直立保管在一个干燥的房间内。

保养与维护

⚠ 伤害危险

在进行所有维护和保养工作前关闭吸尘器并拔下电源线。

清洁设备和附件

⚠ 注意

不使用去污剂、玻璃清洁剂或全能清洁剂！从不将设备浸泡在水中。

清洁打磨垫

→ 每次使用后取下并敲打打磨垫。需要时充分清洗干净并将其干燥。

提示：可以在 60° C 以下的温度下进行机器清洗，不使用柔顺剂，不要在洗衣机中干燥。

→ 将干燥的打磨垫放在存放盒中。

安放过滤袋

请定期更换过滤袋。

→ 为此参见“安放过滤袋”一章。

更换打磨垫

请定期检查打磨垫的状态，一旦磨损，即行更换。

→ 为此参见“放上过滤袋”一章。

一般提示：

质量保证

我们在各国的经销商已经公布了各国相应的质量保证条款。在质量保证期内，如果您的产品发生了任何故障，我们都将为您提供免费维修，但是这种故障应当是由于机身材料或制造上的缺陷造成的。请您向经销商或者与您距离最近的经过授权的客户服务处联系，提出保修请求，并提供相应的产品购买证明文件。
(地址详见背面。)

客户服务

如有疑问或产生故障，我们 KARCHER 公司的分公司将乐于继续帮助您。
(地址详见背面。)

订购备件和选装配件

在说明书的结尾部分您可以找到精选的最频繁需要的备件。
向贵方经销商或向贵处 KARCHER 公司分公司购买备件和附件。
(地址详见背面。)

排除故障帮助

打磨片不安静运转 / 拍打性噪音

- 噪音系受系统条件限制。保管设备时未使用运输保险装置。在打磨过程中经过一定时间后噪音自行消失。

产品规格 / 参数

电压	230	V
电流种类	1~50/60	Hz
保护等级	II	
输入功率	600	瓦
打磨片转速	1000	转 / 分钟
重量	7	千克
外形尺寸	385 x 340 x 1155	毫米
过滤袋容量	4	l

规格若有变更，恕不另行通知。

Contents

Safety instructions	EN . . . 7
Start up	EN . . . 8
Operation	EN . . . 9
Finish operation	EN . . 10
Maintenance and care	EN . . 10
General notes	EN . . 11
Troubleshooting	EN . . 11
Technical specifications	EN . . 11

Dear Customer,



Please read and comply with these instructions prior to the initial operation of your appliance. Retain these operating instructions for future reference or for subsequent possessors.

Proper use

- This appliance has been designed for use in private households and is not intended for commercial use.
- This appliance can be used for polishing parquet, laminate, stone floors, linoleum and PVC floors.
- The appliance is only meant for sucking polishing dust.
- The appliance is not a vacuum cleaner! Do not use to draw in dry dust!
- Do not use care products containing solvents.
- The appliance should not be used on carpets and similar surfaces.
- Do not load down the appliance with additional weights.
- The appliance should not be used or stored in the open or under wet conditions.
- The appliance may only be used with original filter bags, original spare parts, accessories or special accessories.
- Always move the appliance while it is running. Do not stay in one place for extended periods, because this could cause damages to the flooring.
- Please observe the notes of the flooring and care product manufacturers!

The manufacturer is not responsible for any damages that may occur on account of improper use or wrong operations.

Environmental protection



The packaging material can be recycled. Please do not place the packaging into the ordinary refuse for disposal, but arrange for the proper recycling.



Old appliances contain valuable materials that can be recycled. Please arrange for the proper recycling of old appliances. Please dispose your old appliances using appropriate collection systems.

Notes about the ingredients (REACH)

You will find current information about the ingredients at:

www.kaercher.com/REACH

Safety instructions

Power connection

- Always commission and use the appliance according to the type plate.
- Never touch the mains plug with wet hands.
- To separate the machine from the mains, pull the plug and not the power cord.
- Do not damage the power cord or the extension cable by running over, pinching, dragging or similar. Protect the cable from heat, oil, and sharp edges.
- Protect the appliance against external weather, humidity and heat sources.

Application

- *In case of extended downtimes, switch the appliance off at the main switch / appliance switch or remove the mains plug.*
- *This device is not intended for use by persons (including children) with reduced physical, sensory or mental abilities or lacking experience and/or knowledge, unless they are supervised by a person responsible for their safety or are instructed by these persons on*

the use of the device. Children should be supervised, to ensure that they do not play with the device.

- The operator must use the appliance properly. The person must consider the local conditions and must pay attention to third parties, in particular children, when working with the appliance.
- The operator must ensure that no objects that can be sucked in or thrown away by the rotating disc are present in the working area.

Transport

- The engine is to be brought to a standstill and the appliance is to be fastened properly during transportation.

Maintenance

- First pull out the plug from the mains before carrying out any tasks on the machine.
- To avoid risks, all repairs and replacement of spare parts in the machine may only be carried out by the authorised customer service personnel.

Start up

Description of the Appliance

- 1 Polishing head
- 2 Foot switch for strut release
- 3 Strut
- 4 Power cord with plug
- 5 Storage, power cord
- 6 Handle
- 7 Suction hose
- 8 Cloth bag
- 9 Filter bag
- 10 Storage compartment for polishing pads
- 11 Polishing pads
- 12 Pad holder
- 13 Suction hose connection
- 14 Transport rolls
- 15 Attachments for mains cable (4 ea.)
- 16 Transport lock

Remove transport lock

Illustration 1

- Remove the transport locks the first time you use and before using the appliance by pulling them off.

Assemble the strut and attach it

Illustration 2

- Assemble both parts of the strut and secure with the enclosed screw and nut.
- Insert the entire strut into the polishing head and attach with a screw.

Note: Here, take into account the location of the mains cable.

Illustration 3

- Press the mains cable into the attachments and tension it.

Connect suction hose

Illustration 4

- Insert the straight end of the suction hose into the polishing head, insert the bent end into the strut connection.

Inserting the cloth bag

Illustration 5

- First, push the upper part of the cloth bag into the intake until it locks.
- Then attach the bottom part to the strut using the Velcro pad.

Inserting a filter bag

Illustration 6

- Open the zipper of the cloth bag.
- Insert the filter bag and slide the carton with the opening over the support until it locks into place. Recheck the correct positioning of the filter bag.
- Close the zipper on the cloth bag.

Insert pad holder

Illustration 7

- Place the appliance on the floor so that the polishing head is positioned perpendicular to the surface.

- Simply press the pad holder into the intake. Ensure that the noses of the pad holders lock well into the intake.
- To remove the pad holders, simply pull them off.

Insert the polishing pads

Illustration 8

- Install the polishing pads on the pad holders and ensure that they are centered properly.
- To remove the polishing pads, simply pull them off.

Storing the polishing pads

- The polishing pads can be stored in a separate compartment in the bottom part of the cloth bag.

Operation

Note:

Always work with the filter bag inserted.

⚠ Caution

Before inserting the mains plug, ensure that the strut is located in a vertical position. The appliance is switched off in this position.

Illustration 9

- Turn the upper cable hook and remove the mains cable. Insert the mains plug into a socket.

Illustration 10

- Press hold down the unlocking key. Pull the shaft in the rear direction. The device is activated.
- To stop the appliance, bring the strut back to the vertical position until it locks.

Complete care

It is recommended to perform the complete care 2 to 3 times per year.

Remove the dirt from the floor

- Sweep, vacuum or wipe the floor or floor covering with a moist rag if necessary.

Applying care products

- Use a mop to distribute the care product evenly on the floor. Let dry completely
- Notes:** Please observe the instructions for use of the flooring and care product manufacturers!
- Do not use care products containing solvents.

Polishing

Illustration 11

- Drive across the surface multiple times as shown in the illustration until the desired shine is achieved.
- Always move the appliance while it is running. Do not stay in one place for extended periods, because this could cause damages to the flooring.
- Note:** Observe the manufacturer's instructions regarding when to walk on the floor or move furniture, etc. We recommend waiting at least 12 hours. During this period, only walk on the surface carefully and not in street shoes. Do not move any furniture and do not apply water to the floor.

Maintenance care

We recommend performing the maintenance care procedures once per month to achieve an evenly distributed shine.

- Depending on the manufacturer, the care product can be poured directly into the cleaning water. Please observe the instructions for use of the flooring and care product manufacturers!
- Then polish the surface.

Intermediate care

- Depending on the requirements and the use of the floor (foot marks, streaks...), the care coat can be polished multiple times without the need of applying new care products to the floor.

Finish operation

- Bring the strut back to a vertical position. Appliance switches off.

Illustration 12

- Remove the mains plug and wrap it around the hook provided at the strut. First turn the upper cable hook upwards.

Transporting the appliance

Ensure that the appliance moves on the transport wheels while transporting it from one room to another or moving it to its storage location.

Illustration 13

- For this, press handle backwards and pull the appliance.

Storing the Appliance

We recommend activating the transport lock if the appliance will not be used for extended period of time.

Illustration 14

- Place the appliance on the floor so that the polishing head is positioned perpendicular to the surface.
- Remove the pad holder from the appliance and place it into the storage compartment.
- Press the transport lock into the intake of the pad holder on one side and hold it there. Firmly press the other side of the transport lock into the intake of the second pad holder and lock into place.
- Store the appliance upright in a dry room.

Maintenance and care

⚠ Risk of injury

Turn off the appliance and remove the mains plug prior to any care and maintenance works.

Cleaning the appliance and accessories

⚠ Caution

Do not use abrasives, glass or universal cleaners! Never immerse the appliance in water.

Cleaning the polishing pads

- Remove and tap the polishing pads after every use. Wash and dry as needed.
Note: Can be washed at 60 °C; please do not use any soft detergents, do not dry in dryer.
- Place dry polishing pads into the storage compartment.

Inserting a filter bag

Change the filter bag at regular intervals.

- See Chapter "Inserting a filter bag".

Replacing polishing pads

Check the state of the polishing pads at regular intervals; replace them if they are worn out.

- See Chapter "Insert the polishing pads".

General notes

Warranty

The terms of the guarantee applicable in each country have been published by our respective national distributors. We will repair possible faults on your unit free of charge within the warranty period, insofar as the faults are caused by material defects or defective workmanship. Guarantee claims should be addressed to your dealer or the nearest authorized customer service centre, and supported by documentary evidence of purchase.

(See address on the reverse)

Customer Service

Our KÄRCHER branch will be pleased to help you further in the case of questions or faults.

(See address on the reverse)

Ordering spare parts and special attachments

At the end of the operating instructions you will find a selected list of spare parts that are often required.

You can procure the spare parts and the attachments from your dealer or your KÄRCHER branch office.

(See address on the reverse)

Troubleshooting

Discs running unevenly / rattling sound

- This sound is caused by the system. The appliance was not stored with the transport lock activated. This sound will disappear on its own after a while during polishing.

Technical specifications

Voltage	230	V
Current type	1~50/60	Hz
Protective class	II	
Connected load	600	W
Rotating speed, polishing discs	1000	rpm
Weight	7	kg
Dimensions	385 x 340 x 1155	mm
Volume, filter bag	4	l

Subject to technical modifications!







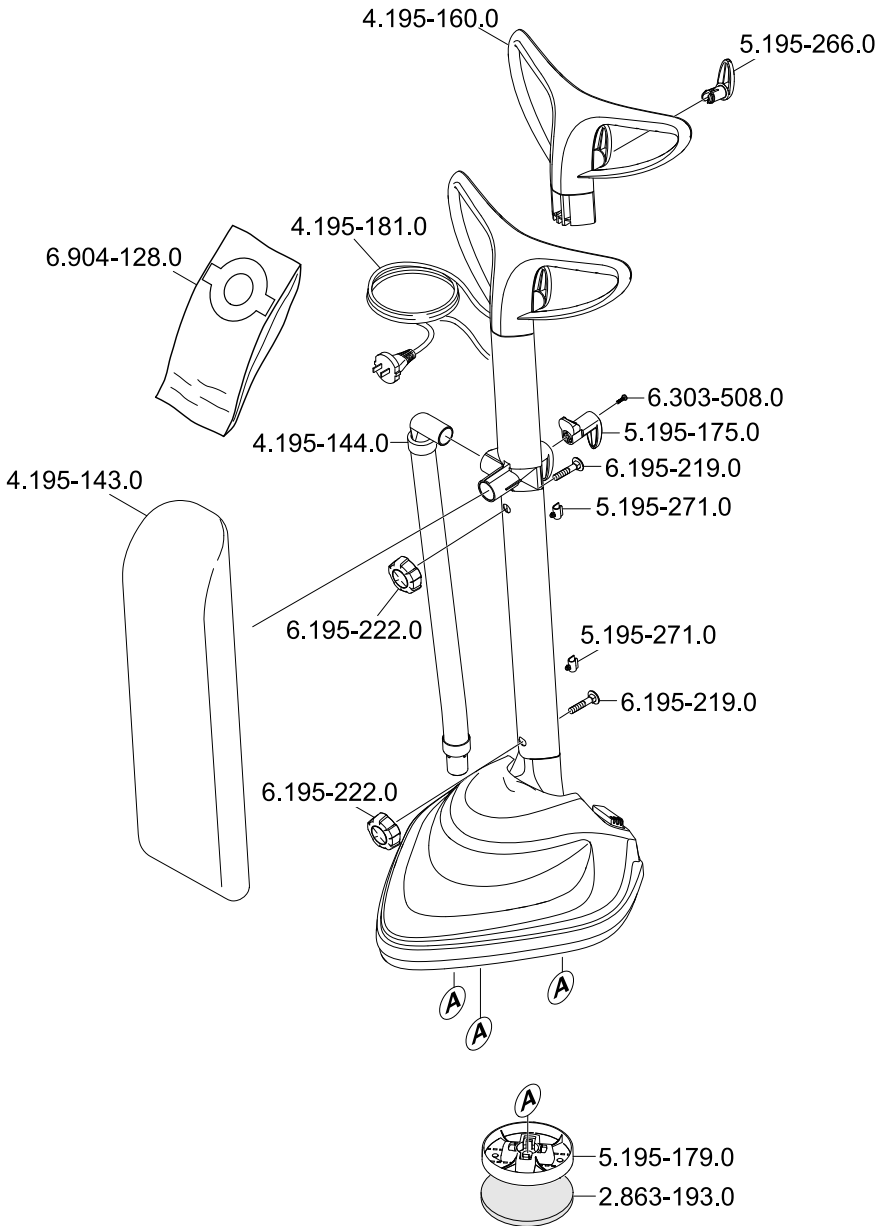



<http://www.kaercher.com/dealersearch>

