

Operating Instructions

Before first use of the unit
read these Operating instructions
and act in accordance with them

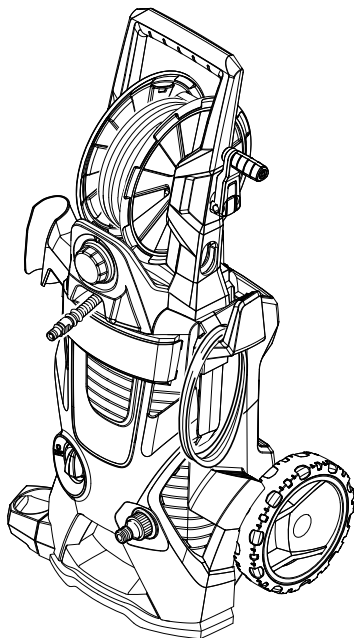

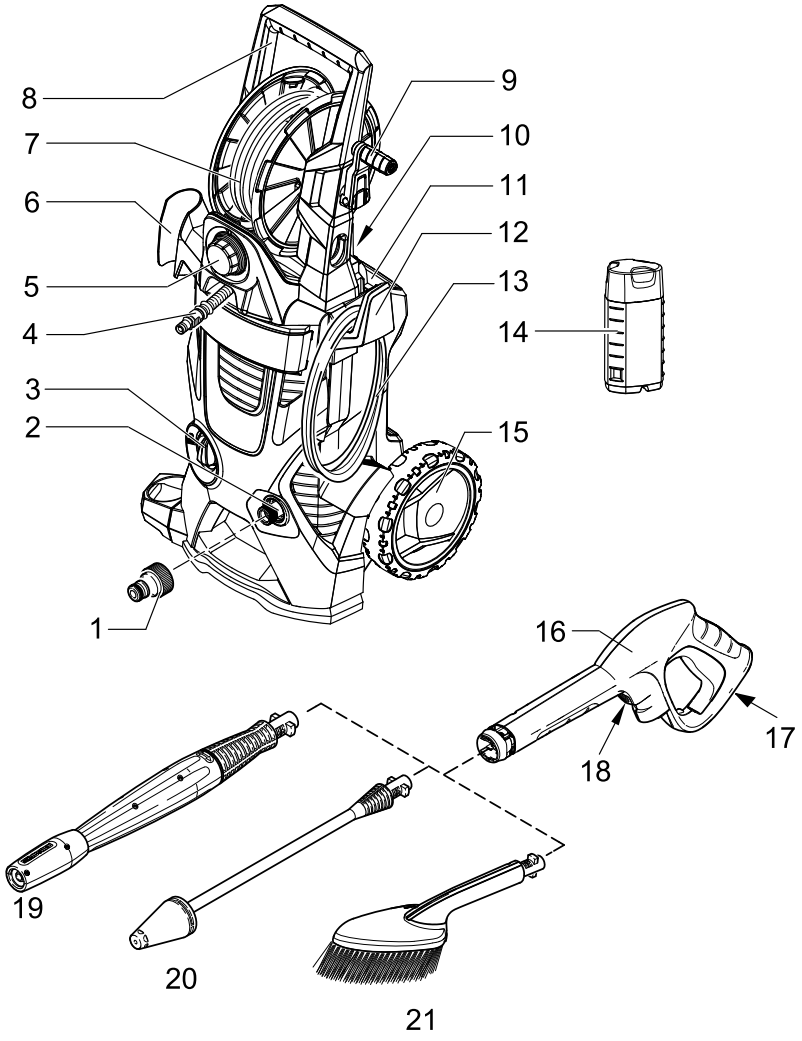

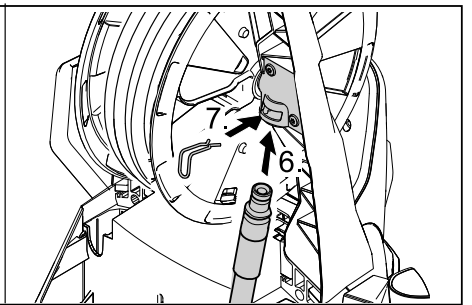
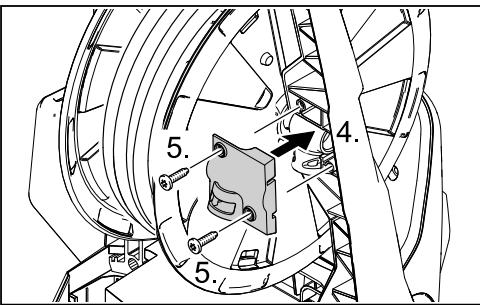
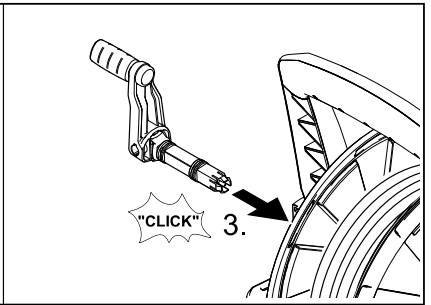
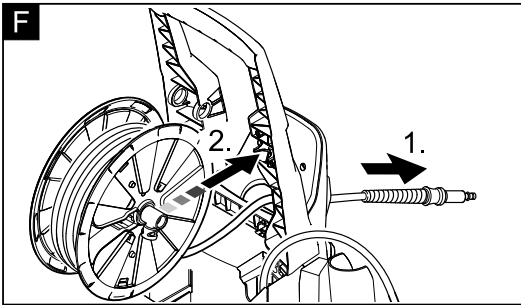
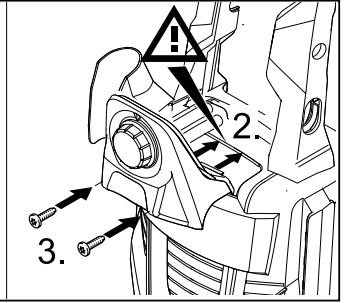
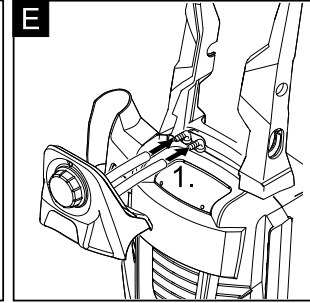
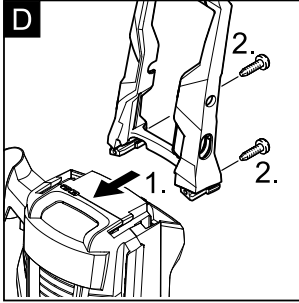
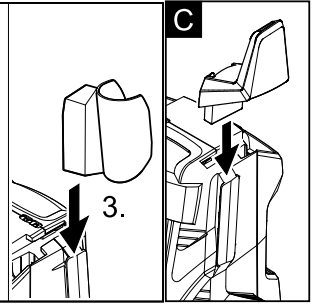
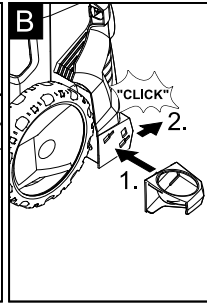
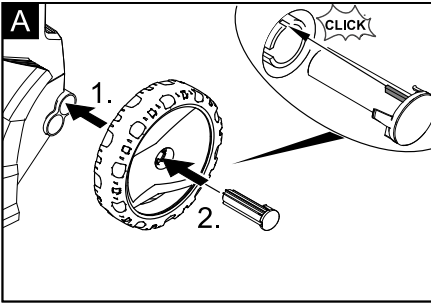

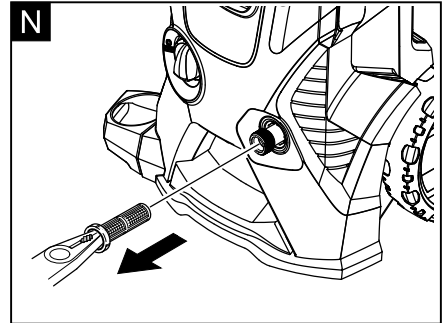
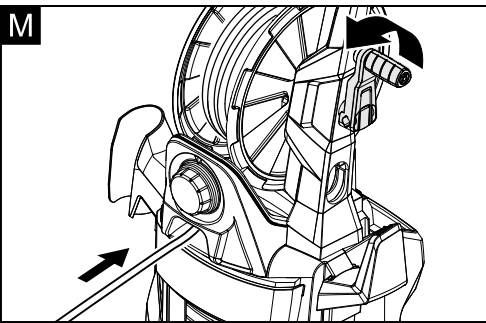
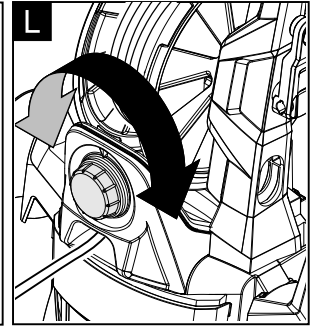
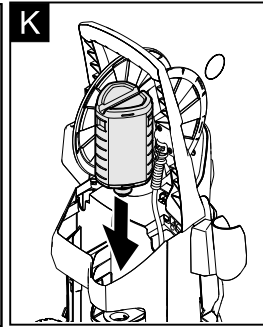
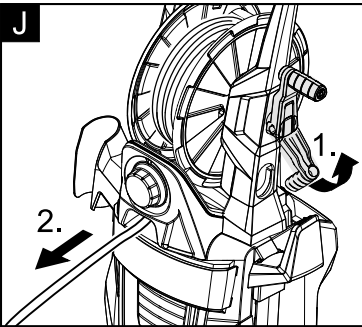
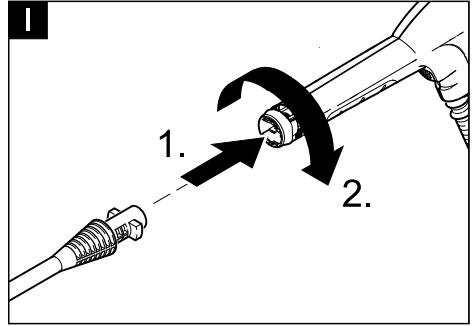
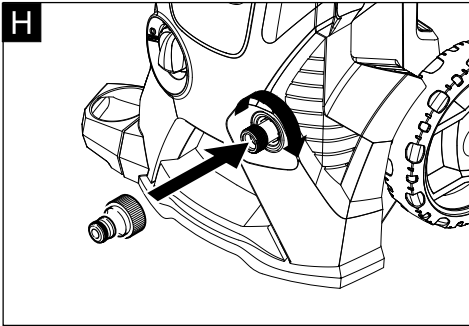
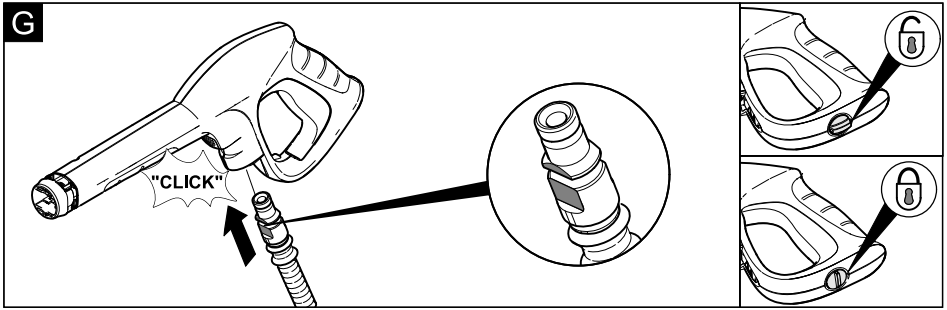



Contents

General information	5
Safety instructions	6
Operation	7
Transport	11
Storage	11
Maintenance and care	11
Troubleshooting	12
Technical specifications	12
Customer Service	12

General information

Dear Customer,

  Please read and comply with these original instructions prior to the initial operation of your appliance and store them for later use or subsequent owners.

Proper Use

This high-pressure cleaner is designed for domestic use only:

- to clean machines, vehicles, buildings, tools, facades, terraces, garden equipment etc. using a high-pressure water jet (and detergents if required).
- with accessories, replacement parts and detergents approved by KÄRCHER. Observe the instructions provided with these detergents.

Environmental protection

 The packaging material can be recycled. Please do not place the packaging into the ordinary refuse for disposal, but arrange for the proper recycling.

 Old appliances contain valuable materials that can be recycled. Please arrange for the proper recycling of old appliances. Please dispose your old appliances using appropriate collection systems.

Notes about the ingredients (REACH)

You will find current information about the ingredients at:

www.kaercher.com/REACH

Warranty

The warranty terms published by the relevant sales company are applicable in each country. We will repair potential failures of your appliance within the warranty period free of charge, provided that such failure is caused by faulty material or defects in manufacturing. In the event of a warranty claim please contact your dealer or the nearest authorized Customer Service centre. Please submit the proof of purchase.

(See address on the reverse)

Symbols in the operating instructions

Danger

Immediate danger that can cause severe injury or even death.

Warning

Possible hazardous situation that could lead to severe injury or even death.

Caution

Possible hazardous situation that could lead to mild injury to persons or damage to property.

Symbols on the machine

- *High-pressure jets can be dangerous if improperly used. The jet must not be directed at persons, animals, live electrical equipment or at the appliance itself.*
- *Frost can destroy the not completely drained appliance. Store the appliance in a frost resistant room during winter.*



Safety instructions

⚠ Danger

- *Never touch the mains plug and the socket with wet hands.*
- *The appliance must not be used if the power cord or important parts of the appliance, e.g. high-pressure hoses, trigger gun or safety devices are damaged.*
- *Check the power cord and mains plug for damage before every use. If the power cord is damaged, please arrange for it to be replaced immediately by an authorised repair agent or a skilled electrician*
- *Check the high-pressure hose for damage before every use. Please arrange for the immediate replacement of a damaged high-pressure hose.*
- *The appliance may not be used in areas where a risk of explosion is present.*
- *If the appliance is used in hazardous areas (e.g. filling stations) the corresponding safety provisions must be observed.*
- *High-pressure jets can be dangerous if improperly used. The jet must not be directed at persons, animals, live electrical equipment or at the appliance itself.*
- *The high-pressure jet must not be directed at other persons or directed by the user at him/herself to clean clothing or footwear.*
- *Never use the appliance to clean objects containing hazardous substances (e.g. asbestos).*
- *Vehicle tyres or tyre valves are susceptible to damage from the high-pressure jet and may burst. The first indication of this is a discolouration of the tyre. Damaged vehicle tyres/tyre valves are highly dangerous. Ensure that a distance of at least 30 cm is observed when cleaning with the jet!*
- *Risk of explosion!
Do not spray flammable liquids.
Never draw in fluids containing solvents or undiluted acids and solvents! This includes petrol, paint thinner and heating oil. The spray mist thus generated is highly inflammable, explosive and poisonous. Do not use acetone, undiluted acids and solvents as they are damaging to the materials from which the appliance is made.*

⚠ Warning

- *The mains plug and the coupling of an extension cable must be watertight and must never lay in the water.*
- *Unsuitable extension cables can be hazardous. Only use extension cables outdoors which have been approved for this purpose and labelled with a sufficient cable cross-section:
1 - 10 m: 1.5 mm²; 10 - 30 m: 2.5 mm²*
- *Always fully unroll electrical cables from the cable drum.*
- *High-pressure hoses, fixtures and couplings are important for the safety of the appliance. Only use high-pressure hoses, fixtures and couplings recommended by the manufacturer.*
- *This appliance is not intended for use by persons with reduced physical, sensory or mental capabilities.
The appliance must not be operated by children or persons who have not been instructed accordingly.
Children should be supervised to prevent them from playing with the appliance.
Keep packaging film away from children - risk of suffocation!*
- *The operator must use the appliance correctly. When working with the appliance, he must consider the local conditions and pay due care and attention to other persons, in particular children, who are nearby.*
- *Do not use the appliance when there are other persons around unless they are also wearing safety equipment.*
- *Wear protective clothing and safety goggles to protect against splash back containing water or dirt.*

Caution

- *In case of extended downtimes, switch the appliance off at the main switch / appliance switch or remove the mains plug.*
- *Do not operate the appliance at temperatures below 0 °C.*
- *Observe a distance of at least 30 cm when using the jet to clean painted surfaces to avoid damaging paintwork.*
- *Never leave the appliance unattended when it is in operation.*

- *Make sure that the power cable or extension cables are not damaged by running over, pinching, dragging or similar. Protect the power cable from heat, oil, and sharp edges.*
- *All current-conducting parts in the working area must be protected against jet water.*
- *The appliance may only be connected to an electrical supply which has been installed in accordance with IEC 60364.*
- *The appliance may only be connected to alternating current. The voltage must correspond with the type plate on the appliance.*
- *For safety reasons, we recommend that you operate the appliance only via a earth-leakage circuit breaker (max. 30 mA).*
- *Cleaning operations which produce oily waste water, e.g. engine washes, underbody washes, may only be carried out using washing stations equipped with an oil separator.*
- *This appliance was designed to be used with detergents which are supplied or recommended by the manufacturer. The use of other detergents or chemicals may compromise the safety of the appliance.*

Safety Devices

Caution

Safety devices protect the user and must not be modified or bypassed.

Power switch

The appliance switch prevents unintentional operation of the appliance.

Lock trigger gun

This lock locks the lever of the trigger gun and prevents the inadvertent start of the appliance.

Overflow valve with pressure switch

The overflow valve prevents the permissible working pressure from being exceeded.

If the lever on the trigger gun is released the pressure switch turns off the pump, the high-pressure jet is stopped. If the lever is pulled the pump is turned on again.

Prerequisites for the appliance's stability

Caution

Create stability for the appliance prior to all work on or with the appliance to prevent accidents or damage.

- The stability of the appliance is warranted when it is placed onto an even surface.

Operation

Scope of delivery

The scope of delivery of your appliance is illustrated on the packaging. Check the contents of the appliance for completeness when unpacking.

In the event of missing accessories or any transport damage, please contact your dealer.

Description of the Appliance

Illustrations on fold-out page!

- 1 Coupling element for water connection
- 2 Water connection with integrated sieve
- 3 Appliance switch "0/OFF"/ „I/ON“
- 4 High pressure hose
- 5 Dosage regulator for detergent
- 6 Storage for trigger gun
- 7 High-pressure hose drum
- 8 Transport handle
- 9 Hand crank for hose drum
- 10 Storage of Plug 'n' Clean detergent bottle with detergent connection
- 11 Storage for accessories
- 12 Storage hook for mains connection cable
- 13 Mains cable with mains plug
- 14 Plug 'n' Clean detergent bottle with locking lid
- 15 Wheels
- 16 Trigger gun
- 17 Lock trigger gun
- 18 Key to detach the high pressure hose from the trigger gun
- 19 Spray lance with pressure regulation (Vario Power)
- 20 Spray lance with Dirtblaster
- 21 Washing brush



Special accessories

Special accessories expand the possibilities of using your appliance. Please contact your KÄRCHER dealer for further information.

Before Startup

Mount loose parts delivered with appliance prior to start-up.

Install wheels

→ Illustration **A**

Push the wheels into the intake and secure with the enclosed plugs, watch for positioning of plug.

Install the storage for hand-spray gun

→ Illustration **B**

Place the bottom holder into the recesses and push forward until it audibly locks in. Insert the top holder and push down all the way.

Install the storage hook for the mains connection cable

→ Illustration **C**

Press in the storage hook and lock it into the top position.

Install the transport handle

You will need the 2 included screws as well as a Philips screwdriver PH 2.

→ Illustration **D**

Slide the transport handle into the guide and secure it with 2 screws.

Install the dosage regulator for detergent

You will need the 2 included screws as well as a Philips screwdriver PH 2.

→ Illustration **E**

Insert both detergent hoses onto the hose fittings.

Install the dosage regulator and connect using 2 screws.

Note: During installation you must make sure that the tongues of the dosage regulator match up with the intended recesses in the casing.

Install the high pressure hose drum

→ Illustration **F**

Slide the free end of the coiled high pressure hose through the recesses on the dosage regulator.

Insert the hose drum into the intakes on the transport handle.

Insert the axle of the hand crank into the guides.

Install the fixating plate and secure it using 2 screws.

Press the connecting fitting from the short high pressure hose into the brass intake, secure with clamps.

Note: Make sure the connection nipple is aligned correctly.

Connect the high pressure hose to the hand spray gun

→ Illustration **G**

Push the high pressure hose into the trigger gun until it locks audibly.

Note: Make sure the connection nipple is aligned correctly.

Check the secure connection by pulling on the high pressure hose.

Water supply

Warning

According to the applicable regulations, the appliance must never be used on the drinking water supply without a system separator. Use a suitable system separator manufactured by KÄRCHER; or, as an alternative, a system separator as per EN 12729 Type BA. Water flowing through a system separator is considered non-drinkable.



Caution

Always connect the system separator to the water supply, never directly to the appliance!

Note: Impurities in the water can damage the high-pressure pump and accessories. For protection, the use of the KÄRCHER water filter (optional accessory, order no. 4.730-059) is recommended.

Water supply from mains

Observe regulations of water supplier.

For connection values, see type plate/technical data.

→ Use a fibre-reinforced water hose (not included) with a standard coupling. (Minimum diameter 1/2 inch (13 mm), minimum length 7.5 m).

→ Illustration **H**

Screw the supplied coupling element to the water connection on the appliance.

Push the water supply hose onto the coupling unit, then connect it to the water supply.

How to draw water from a bucket when using a KÄRCHER Pressure Cleaner

KÄRCHER recommends using the suction hose accessory (sold separately) Order no. 9.505-779.0.

STEP 1:

- Connect the suction hose to the water inlet on the pressure cleaner and drop the other end into a bucket.

Tip: If you are not using this accessory, coil a hose into the bucket and ensure that you only use a standard hose clamp to connect to the pressure washer.

CLICK FITTINGS MUST NOT BE USED!

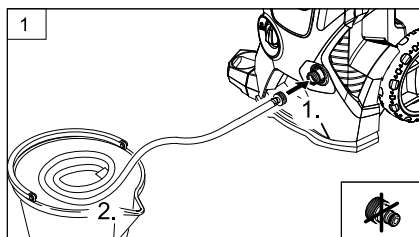

STEP 2:

- Fill up your bucket with water.

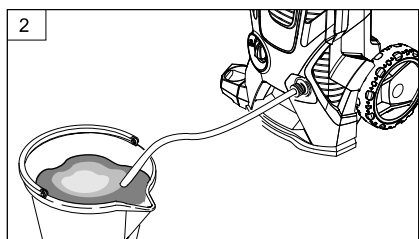

STEP 3:

- Connect the KÄRCHER power cord to an electricity source and turn on at power-point. Make sure the high pressure nozzle is not connected and turn the unit on at the ON/OFF switch. Press the trigger on the gun - the unit is ready for use once there is a constant water system.

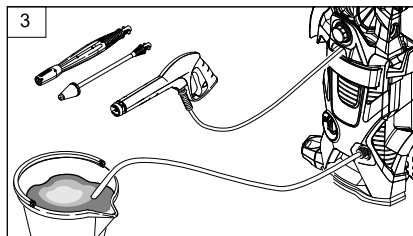

STEP 4:

- Connect the high pressure nozzle and press the hand trigger to begin cleaning.

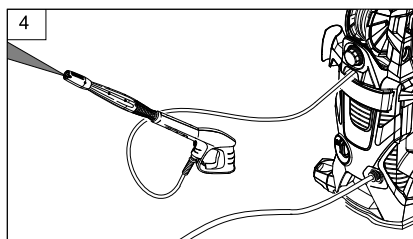

Start up

Caution

Dry runs lasting longer than two minutes lead to damages to the high pressure pump. If the appliance does not build up pressure within two minutes, switch it off and proceed as instructed in the Chapter "Troubleshooting".

- Illustration **I**

Push the spray lance into the trigger gun and fasten it by turning it through 90°.

- Illustration **J**

Unwind the high pressure hose from the hose drum. Hold on to the transport handle during this procedure.

Note: If the hand crank is in its secured position, fold it up first.

- Completely open the water tap.
- Insert the mains plug into the socket.
- Turn on the appliance "I/ON".

High pressure operation

Danger

The trigger gun is subjected to a recoil force when the water jet is discharged. Make sure that you have a firm footing and are also holding the trigger gun and spray lance firmly.

Caution

Prior to cleaning, make sure that the high pressure is placed safely on level ground. Wear protective goggles and protective clothing during the cleaning process.

- Unlock the lever on the trigger gun.
- Pull on the lever of the trigger gun; the device will switch on.

Note: Release the lever of the trigger gun; the device will switch off again. High pressure remains in the system.

Spray lance with pressure regulation

Carrying out the most common cleaning tasks. The work pressure can be stagelessly regulated between "Min" and "Max".

- Release the lever on the trigger gun.
- Turn the spray lance to the desired position.

Note: Suitable for working with detergent; for this, turn the spray lance to the "Mix" position.

Spray lance with Dirtblaster

For particularly dirty items or areas.

- Not suitable for use with detergents.

Washing brush

Suitable for use with detergents.

Caution

Car tyres, paint or sensitive surfaces such as wood should not be cleaned with the dirt blaster, as there is a risk of damage.

Working with detergent

Please use exclusively KÄRCHER detergents and care products to carry out the respective cleaning task, as these were specifically developed for your appliance. The use of other detergents and care products may lead to premature wear and can invalidate your warranty claims. Please obtain information at your local dealer or request information directly from KÄRCHER.

Notes regarding the detergent: The most commonly used KÄRCHER detergents can be purchased ready to use in their Plug 'n' Clean detergent bottles with locking lids. This will make the pesky refilling and filling processes redundant.

→ Illustration K

Remove the lid from the Plug 'n' Clean detergent bottle and press the detergent bottle into the detergent connection with the opening facing down.

→ Illustration L

Adjust the suction volume of the detergent solution by means of the dosage regulator for detergents.

→ Use spray lance with pressure regulation (Vario Power).

→ Turn the spray lance to "Mix" position.

Note: This will mix the detergent with the water stream.

Note: If required, the washing brushes can be used to work with detergent.

Recommended cleaning method

- Spray the detergent sparingly on the dry surface and allow it to react, but not to dry.
- Spray off loosened dirt with the high-pressure jet.

Interrupting operation

- Release the lever on the trigger gun.
- Lock the lever on the trigger gun.
- During longer breaks (more than 5 minutes), also turn the appliance off using the "0/OFF" switch.
- Insert the trigger gun in its holder.

Finish operation

Caution

Only separate the high-pressure hose from the trigger gun or the appliance while there is no pressure in the system.

- Remove the Plug 'n' Clean detergent bottle from the intake and close it with the lid. To store, place into the intake rotated by 180°.
- Release the lever on the trigger gun.
- Turn off the appliance "0/OFF".
- Turn off tap.

- Detach the appliance from the water supply.

Caution: When disconnecting the supply or high pressure hose, warm water may leak from the connections after operation.

- Press the lever on the trigger gun to release any remaining pressure in the system.
- Lock the lever on the trigger gun.
- Pull out the mains plug.

Transport

Caution

In order to prevent accidents or injuries, keep in mind the weight of the appliance during transport (see Specifications).

When transporting by hand

- Lift appliance by the carrying handle and carry it.
- Pull the appliance by its transport handle.

When transporting in vehicles

- Prior to horizontal transport: Remove the Plug 'n' Clean detergent bottle from the intake and close it with the lid.
- Secure the appliance against shifting and tipping over.

Storage

Caution

In order to prevent accidents or injuries, keep in mind the weight of the appliance when selecting a storage location for it (see Specifications).

Storing the Appliance

- Park the machine on an even surface.
- Illustration  Wind the entire high pressure hose onto the hose drum by rotating the hand crank counter-clockwise.
- Insert the hand spray gun with the spray lance into the holder for the hand spray gun.
- Stow away the mains cable and accessory at the machine. Store the appliance in a dry room.

Frost protection

Caution

Protect the appliance and its accessories against frost.

The appliance and its accessories can get destroyed through frost if there are any water residues in them. To avoid damage to them: Completely drain all water from the appliance:

- Detach the appliance from the water supply.
- Detach spray lance from the trigger gun.
- Switch the appliance on ("I/ON"), press the trigger gun lever until no further water is discharged (approx. 1 min).
- Turn off the appliance.
- Store the appliance and the entire accessories in a frost-safe room.

Maintenance and care

Danger

Turn off the appliance and remove the mains plug prior to any care and maintenance work.

Maintenance

The appliance is maintenance-free.

Care

Prior to longer periods of storage, e.g. in the winter:

- Completely drain all water from the appliance:
(for a description, see section on "Frost protection")
- Illustration  Pull out the sieve in the water connection using flat-nose pliers and clean under running water.

Spare parts

Use only original KÄRCHER spare parts. You will find a list of spare parts at the end of these operating instructions.

Troubleshooting

You can rectify minor faults yourself with the help of the following overview.

If in doubt, please consult the authorized customer service.

Danger

Turn off the appliance and remove the mains plug prior to any care and maintenance work. Repair works may only be performed by the authorized customer service.

Appliance is not running

- Pull on the lever of the trigger gun; the device will switch on.
- Check whether the voltage indicated on the type plate corresponds to the voltage of the mains supply.
- Check the mains connection cable for damages.

Pressure does not build up in the appliance

- Check setting at the spray lance.
- Remove air from appliance before operation.

Switch on the appliance without connection the HP hose (max. 2 minutes) and run it until the water discharging from the HP outlet is free of bubbles. Switch off appliance and reconnect HP hose.

- Check the water supply.
- Pull out the sieve in the water connection using flat-nose pliers and clean under running water.

Appliance does not start, motor hums

Cause: Voltage reduction due to weak mains supply or when using an extension cable.

- When switching on, first pull the lever of the trigger gun and then switch the appliance switch to "I/ON".

Strong pressure fluctuations

- Clean high-pressure nozzle: Remove dirt and debris from the nozzle bore, using a needle and rinse through with water from the front.
- Check water flow quantity.

Appliance is leaking

- Slight leakage from the appliance pump is normal. If the leakage increases contact the authorized customer service.

No detergent infeed

- Use spray lance with pressure regulation (Vario Power).
Turn the spray lance to "Mix" position.
- Check the settings at the dosage regulator for detergent.
- Check the detergent suction hose for kinks.

Technical specifications

Power connection		
Voltage	240	V
1~50 Hz		
Connected load	2,0	kW
Mains fuse (slow-blow)	10	A
Protective class	I	
Protection class	IP X5	
Water connection		
Max. feed temperature	40	°C
Min. feed volume	10	l/min
Max. feed pressure	0,8	MPa
Max. Suction height	0,5	m
Performance data		
Working pressure	12	MPa
Max. permissible pressure	14	MPa
	2030	PSI
Water flow rate	7,5	l/min
Detergent flow rate	0 - 0,3	l/min

Subject to technical modifications!

Customer Service

Australia

KÄRCHER Pty. Ltd.
40 Koornang Road
Scoresby, Victoria 3179

1800 675 714 (Free Call)
www.karcher.com.au

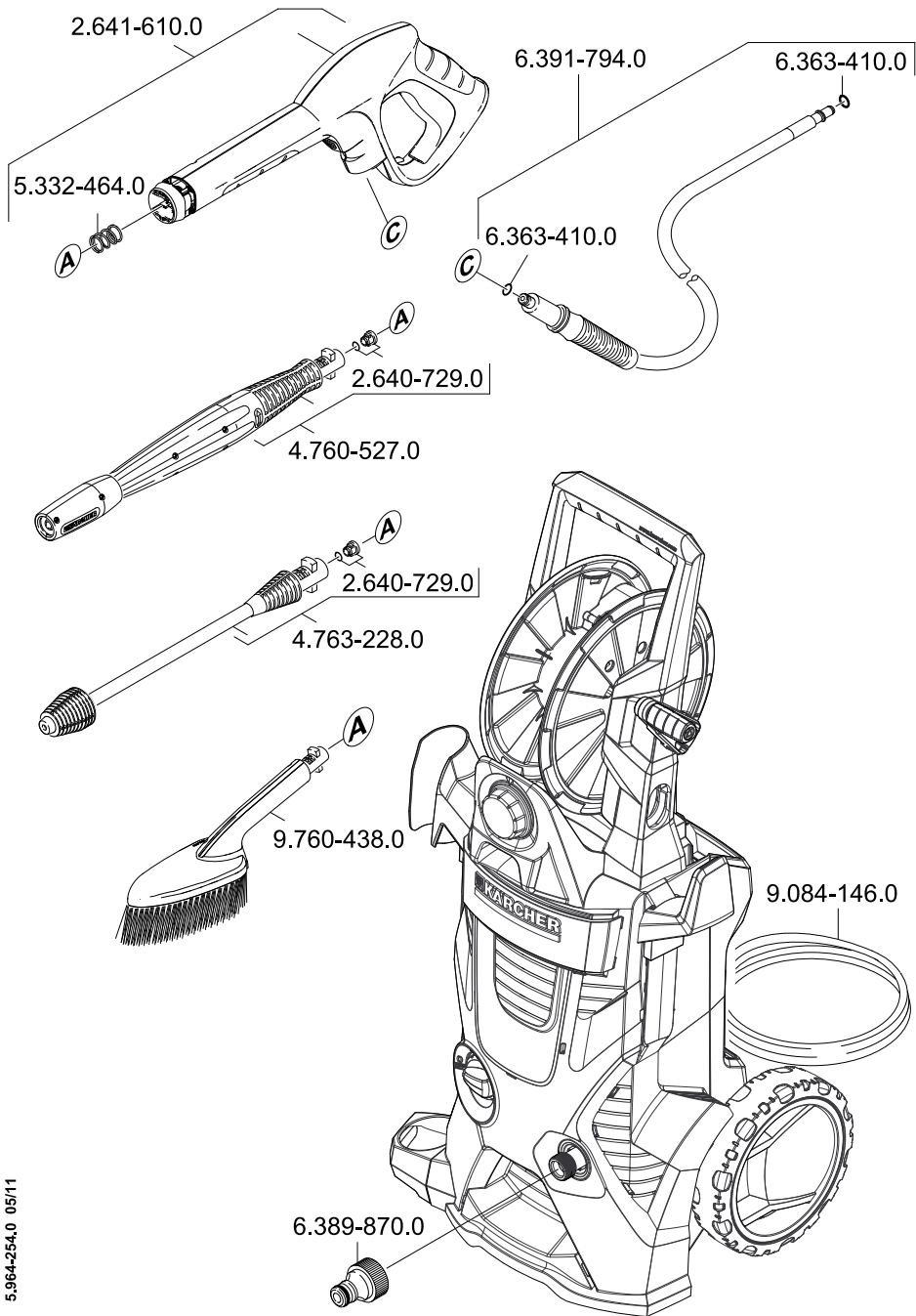



www.karcher.com.au